

F. H. RICHARDS.
TURRET MECHANISM FOR LATHES.

No. 480,963.

Patented Aug. 16, 1892.

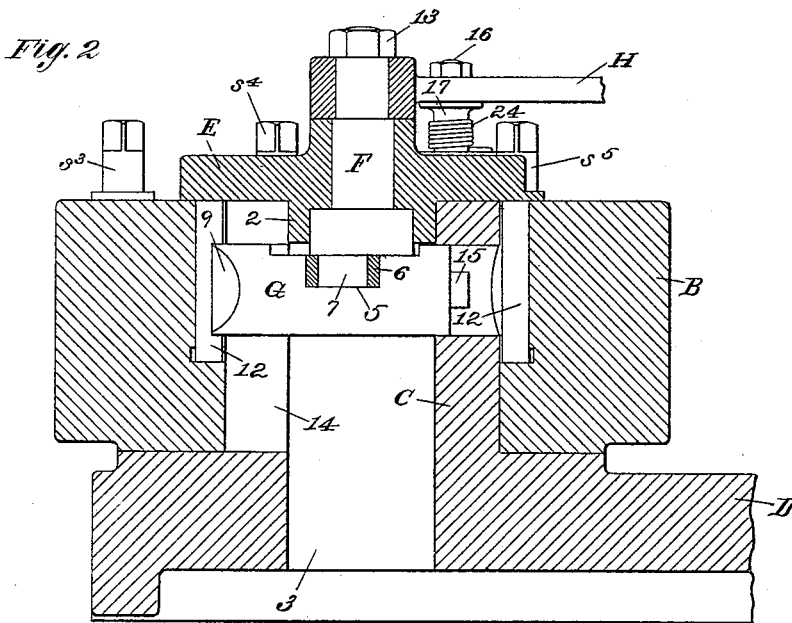
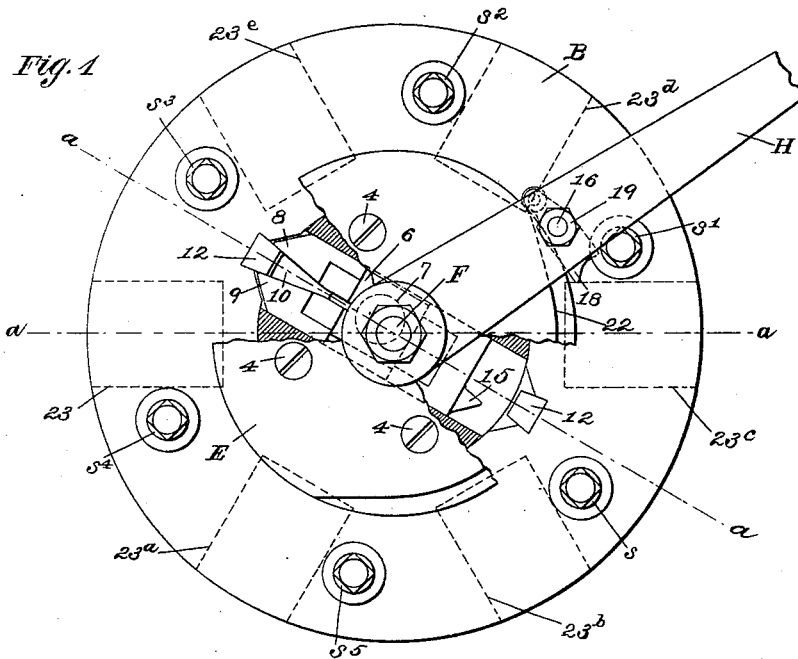

Witnesses:
H. Mullner.
Henry L. Rickard.

Inventor:
Francis H. Richards

F. H. RICHARDS.
TURRET MECHANISM FOR LATHES.

No. 480,963.

Patented Aug. 16, 1892.

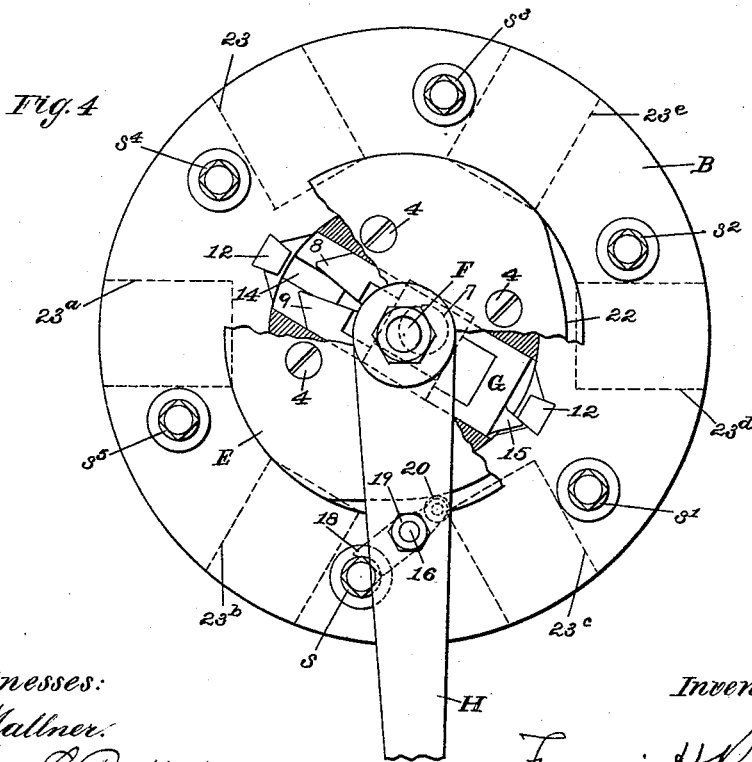
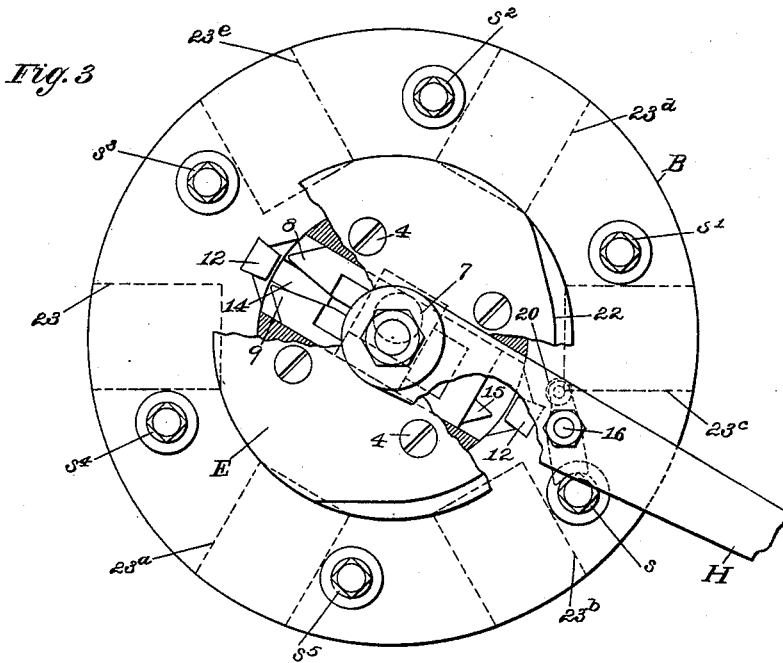

Witnesses:

H. Mullner.
Henry L. Reekard.

Inventor:

Francis H. Richards.

F. H. RICHARDS.
TURRET MECHANISM FOR LATHES.

No. 480,963.

Patented Aug. 16, 1892.

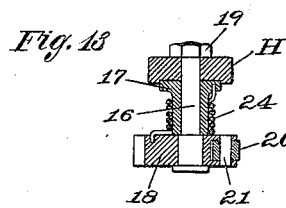
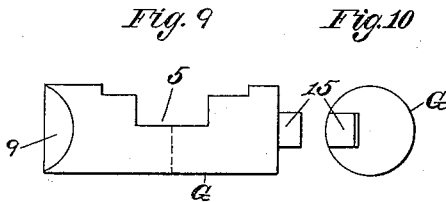
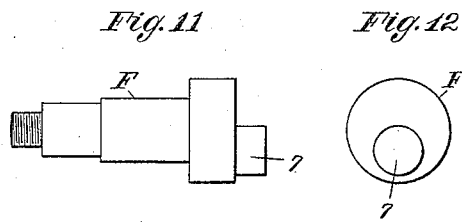
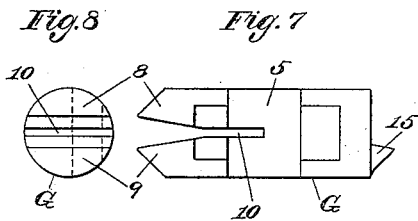
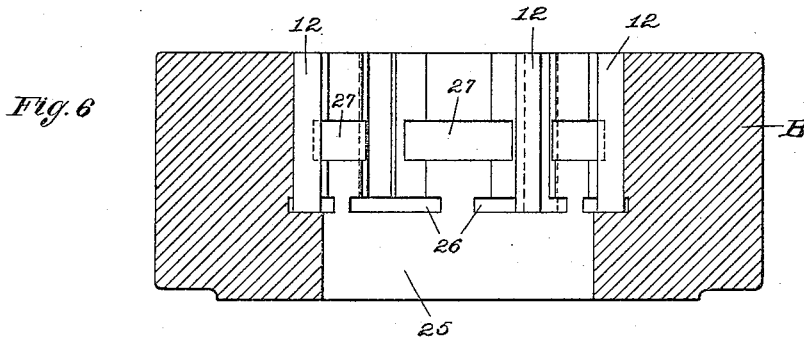
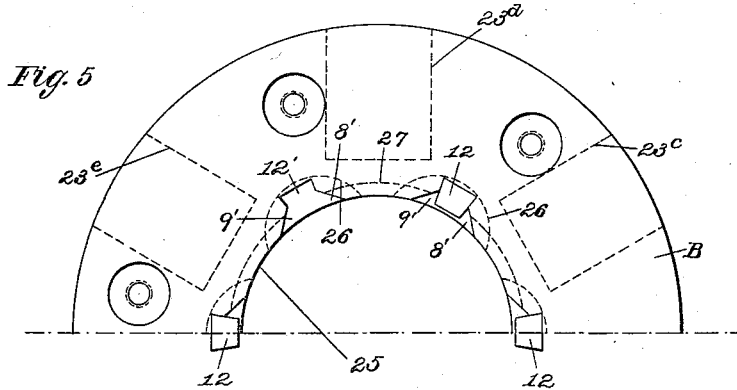

Witnesses:

H. Mallner.
Henry L. Richards.

Inventor:

Francis H. Richards.

UNITED STATES PATENT OFFICE.

FRANCIS H. RICHARDS, OF HARTFORD, CONNECTICUT, ASSIGNOR TO WALTER WOOD, OF PHILADELPHIA, PENNSYLVANIA.

TURRET MECHANISM FOR LATHES.

SPECIFICATION forming part of Letters Patent No. 480,963, dated August 16, 1892.

Application filed November 23, 1891. Serial No. 412,866. (No model.)

To all whom it may concern:

Be it known that I, FRANCIS H. RICHARDS, a citizen of the United States, residing at Hartford, in the county of Hartford and State of Connecticut, have invented certain new and useful Improvements in Turret Mechanisms for Lathes, of which the following is a specification.

This invention relates to turret mechanisms for lathes, and is in part in the nature of an improvement on the turret-clamping mechanism described and claimed in my concurrent application, Serial No. 412,871, filed November 23, 1891.

The object of my present invention is to provide for simultaneously locking and clamping the turret of a turret-lathe by means of a single apparatus therefor.

In the drawings accompanying and forming a part of this specification, Figure 1 is a top or plan view of a lathe-turret furnished with my improved locking mechanism, some parts being broken away the better to show the construction and operation of the several details. Fig. 2 is a vertical section in line *aa* of Fig. 1, showing, also, a portion of the usual turret-slide. Figs. 3 and 4 are views similar to Fig. 1, each showing the parts in different positions. Fig. 5 is a plan view of one-half of the turret with the minor parts removed therefrom. Fig. 6 is a vertical section of the turret, drawn in projection with Fig. 5. Fig. 7 is a plan view of the lock-bolt. Fig. 8 is an end elevation of the lock-bolt as seen from the left hand in Fig. 7. Fig. 9 is a side elevation of the lock-bolt, drawn in projection with Fig. 7. Fig. 10 is an end elevation of the lock-bolt as seen from the right hand in Fig. 9. Fig. 11 is a side elevation of the bolt-actuating crank-shaft. Fig. 12 is an end elevation of the crank-shaft as seen from the right hand in Fig. 11. Fig. 13 is a vertical sectional view through the hand-lever and the turret-actuating pawl carried thereon.

Similar characters designate like parts in all the figures.

My improved turret mechanism consists, essentially, of an expansible column, a turret revolubly mounted on said column and having notches, keys, or abutments whereby it may be locked in successive positions, and

turret-locking means, as a lock-bolt or the like, for simultaneously locking the turret and expanding the column within the same. For actuating the lock-bolt any suitable means—as, for instance, a cam or crank—may be provided, and for operating said bolt-actuating means a hand-lever is deemed preferable.

In the drawings the turret, which is designated in general way by B, is shown revolubly mounted upon a column C, that is or may be formed integral with the usual turret-slide, a portion of which slide is shown in section in Fig. 2 and there designated by D. The turret B is shown arranged for carrying six tools, (the more frequent number,) and the turret actuating and locking mechanism is shown constructed and arranged for bringing each of the six tools successively into proper working position. The operation of this mechanism is independent of the advancing or retracting movements of the turret-slide. The turret is held in place on the column C by means of a cap E, whose hub 2 fits into the upper end of the bore 3 of said column. Said cap is shown secured to the column by means of suitable screws, as 4, and forms the bearing for the crank-shaft F.

The vertical column C is bored crosswise thereof to receive the sliding lock-bolt G, (shown in detail in Figs. 7, 8, 9, and 10,) which has a mortise 5 formed therein to receive the sliding crank-pin block 6, that is carried by the crank-pin 7 of the crank-shaft F. The lock-bolt G is bifurcated or duplex, being split from the forward or left-hand end thereof for about one-half its length to permit of the spreading apart of the oppositely-disposed turret-engaging ends 8 and 9. The sides of the groove or opening 10 between said ends 8 and 9 are beveled for a portion of their length to exactly fit the correspondingly-shaped lock-bolt-expanding keys or abutments 12, which are rigidly fixed in the turret. For actuating the crank-shaft F this is provided with a lever H, which is fixed to the upper end of said shaft by means of a nut 13. By means of this lever the operator may turn the crank to advance or retract the lock-bolt. By pushing the lever from him into the position shown in Fig. 1 the operator throws the lock-bolt forward to-

ward the left hand into engagement with one of the wedges 12, which, entering the opening 10 of the bolt, spreads apart the ends 8 and 9 thereof, and thus expands the stud C within the turret, thereby doubly securing said turret in position, to facilitate which purpose the column C is split on one side, as at 14, to permit of said expansion. A projection or stop 15 is formed on the right-hand end of the lock-bolt to limit the forward movement of the turret by engaging one of the wedges 12 when said bolt is fully retracted, as shown in Fig. 4. The lever H serves, also, after the partial retraction of the lock-bolt as a means for turning forward the turret. For this purpose said lever is provided with a stud 16, furnished with a collar or thimble 17 and carrying a pawl 18, the parts being held in place by means of the nut 19. (See Fig. 13.) The pawl 18 is or may be provided with a roller 20, carried by a pin 21, fixed in said pawl. A spiral spring 24, carried upon the thimble 17, (one end being fixed in said thimble and the opposite end in the pawl 18,) normally holds the roll 20 of said pawl against the periphery of the cap E or against the cam-face 22, formed thereon. A series of studs (in the present case six in number) to correspond with the number of tool-sockets 23, formed in the turret, as indicated by dotted lines in the drawings, and designated by $s, s', s^2, s^3, s^4,$ and s^5 , is fixed in the turret B, the pawl 18 engaging said studs after the manner of a ratchet to rotate the turret. In practice the studs s are the upper ends of the binding-screws used for holding the tools (not herein shown) in place in the turret.

The preferred construction of the turret, whereby it is fitted to receive the keys or abutments 12, and whereby the proper operation in connection with said keys of the lock-bolt G is provided for, is illustrated in Figs. 5 and 6. When making the turret, after the bore 25 thereof is finished a series of milling cuts, as 26, are made therein, and keyways, as 12'—one for each of the keys 12—are formed, extending from the upper side of the turret downward to said cuts 26, said cuts being only for facilitating the making of the keyways. Into these keyways the keys 12, usually and preferably of steel suitably tempered, are firmly driven or forced by means of a fitting-press or otherwise. At the sides of said keys the turret is cut away to form the spaces 8' 9', Fig. 5, for receiving the aforesaid turret-engaging ends 8 and 9, respectively, of the lock-bolt. A groove 27, Figs. 5 and 6, is formed on the inner side of the turret, substantially as shown, for receiving the rearward projection 15 of the lock-bolt at the time when this bolt is being retracted from its position in Fig. 3 to its position in Fig. 4. When constructed as here described, the turret-abutments 12 lie entirely outside of the turret-supporting column C. The keys 12 may be integral with the turret when this is made of suitable material therefor.

The general operation of the mechanism is as follows: In Fig. 1 the turret is shown locked in proper position for holding the tool-socket 23 in the "working position," and the crank-lever is shown in its corresponding position, being thrown back farthest from the operator. It being now desired to bring the next tool-socket 23^a into that position, the operator grasps the lever H and pulls it toward him. During the forward stroke of said lever, the roll 20 of the pawl 18 riding on the periphery of the cap E, said pawl is thereby prevented from engaging the stud s' ; but as the lever is drawn farther forward said roll passes onto the cam-face 22, and the pawl 18 is by means of the spring 24 brought into its working position ready to engage the pin or stud s . On the first forward movement of said lever from its position in Fig. 1 to its position in Fig. 3 the lock-bolt G is drawn back by means of the aforesaid crank-pin 7 and the turret is unlocked. At the same time the pawl 18 engages the stud s . The operator continuing to pull forward the lever, the turret is turned on its pivot-column C and brought into the position shown in Fig. 4, bringing the socket 23^a into working position. During the moving of the lever from its position in Fig. 3 to its position in Fig. 4 the lock-bolt is drawn farther back until the projection 15 on the rear end thereof engages one of the turret-wedges 12, thus preventing any further forward movement of the turret and leaving this in the position for locking. The lever H is next thrown back to the position shown in Fig. 1, the two ends 8 and 9 of the lock-bolt engaging the sides of the next key, and, being spread thereby, forcibly expanding the turret-column within the central bore 25 of the turret. By means of the wedge shape of the key 12 and of the corresponding opening 10 in the lock-bolt the play due to imperfect fitting or wear between the key and lock-bolt is taken up, and by the expansion due to its being forced upon the tapered key any play or wear normally existing between the lock-bolt and the walls of the column is also taken up, and as a result of the expansion of the bolt to take up its play, as aforesaid, the column C is itself expanded within the bore 25 of the turret, so that on the complete locking of the turret by forcing the lever to its position shown in Fig. 1 all of the said interlocking parts are forced or abutted the one upon the other, thereby taking up all play and freedom of fitting and producing a firm and rigid locking and clamping of the turret. The position of the crank-pin 7 (shown by a dotted line in Fig. 1) relatively to the line of movement $a a$, Fig. 1, of the lock-bolt when the lock-bolt is forced into engagement with the key 12, as in Figs. 1 and 2, should be adjacent to the true "dead-center" of said crank, so that the crank-shaft F is thereby effectively held by the friction of the parts in position for preventing retraction of the lock-bolt without any necessity for using auxiliary devices for so retaining said shaft.

Having thus described my invention, I claim—

1. In a turret mechanism, the combination, with an expansible column fitted to receive the lock-bolt, of the turret revolubly mounted on said column and having a key, substantially as described, the lock-bolt constructed to engage said key and to be expanded thereby, and means for forcing the lock-bolt upon the key to expand the bolt within the expansible column, whereby the turret is simultaneously locked and clamped, substantially as described.

2. In a turret mechanism, the combination, with the expansible column constructed to receive the lock-bolt, of the turret revolubly mounted on said column and having a lock-bolt-expanding key, the lock-bolt constructed to engage said key and be expanded thereby, a shaft having a crank engaging the lock-bolt and standing adjacent to the dead-center when the turret is locked, and means for turning said shaft to engage and disengage the lock-bolt with and from said key, whereby the turret is simultaneously locked and clamped and the lock-bolt frictionally held from retraction, substantially as described.

3. In a turret mechanism, the combination, with the expansible column fitted to receive the lock-bolt, of the turret revolubly mounted on said column and having a series of wedge-shaped keys, the expansible lock-bolt constructed at one end to engage said key and at the other end having a stop, substantially as described, and means for first actuating said bolt to withdraw the same from one of said keys and afterward to turn forward the turret and bring said stop into engagement with another of said keys, substantially as described.

4. In a turret mechanism, the combination, with the expansible column constructed to receive the lock-bolt, of the turret revolubly mounted on said column and having a lock-

bolt-expanding key, the lock-bolt fitted to slide in said column to engage said key and be expanded thereby, the cap fixed to the column for retaining the turret thereon, and the crank-shaft journaled in said cap and having a crank-pin engaging the lock-bolt to slide the same from and into engagement with said key, and means for turning said shaft, substantially as described.

5. In a turret mechanism, the combination, with the expansible column constructed to receive the lock-bolt, of the turret revolubly mounted on said column and having keys, substantially as described, the lock-bolt fitted to slide in said column from and into engagement with said keys, a series of studs on the turret corresponding to said keys, the lever carrying a pawl adapted to engage said studs for turning the turret, and means, substantially as described, intermediate to the lever and lock-bolt and constructed to withdraw said bolt from the key prior to the engagement of the pawl with a turret-stop, substantially as described.

6. In a turret mechanism, the combination, with the expansible column constructed to receive the lock-bolt, of the turret revolubly mounted on said column and a column-expanding lock-bolt engaging the turret to lock the same from rotation, substantially as described.

7. In a turret mechanism, the combination, with the revoluble turret having a series of studs, substantially as described, of the cap having the cam-face, the lever, the pawl carried on said lever and adapted to engage said studs, and means for swinging the pawl into working position against said cam-face, substantially as shown and described.

FRANCIS H. RICHARDS.

Witnesses:

HENRY L. RECKARD,
HANS MALLNER.